

COMPT.	DOOR OPENING	INTERIOR	DIVIDE HEIGHT	LOWER DEPTH	LOWER
L1	49"W x 57"H	54.5"W x 73.5"H	30"	14"	25"
L2	29"W x 23"H	42.5"W x 39.5"H	-	14"	14"
L3	48"W x 17"H	51"W x 28.5"H	-	14"	14"
L4	27"W x 53"H	37"W x 64.5"H	26"	14"	24"
R1	49"W x 57"H	54.5"W x 73.5"H	30"	14"	25"
R2	29"W x 23"H	42.5"W x 39.5"H	-	14"	14"
R3	48"W x 17"H	51"W x 28.5"H	-	14"	14"
R4	51"W x 53"H	58.5"W x 64.5"H	26"	14"	24"

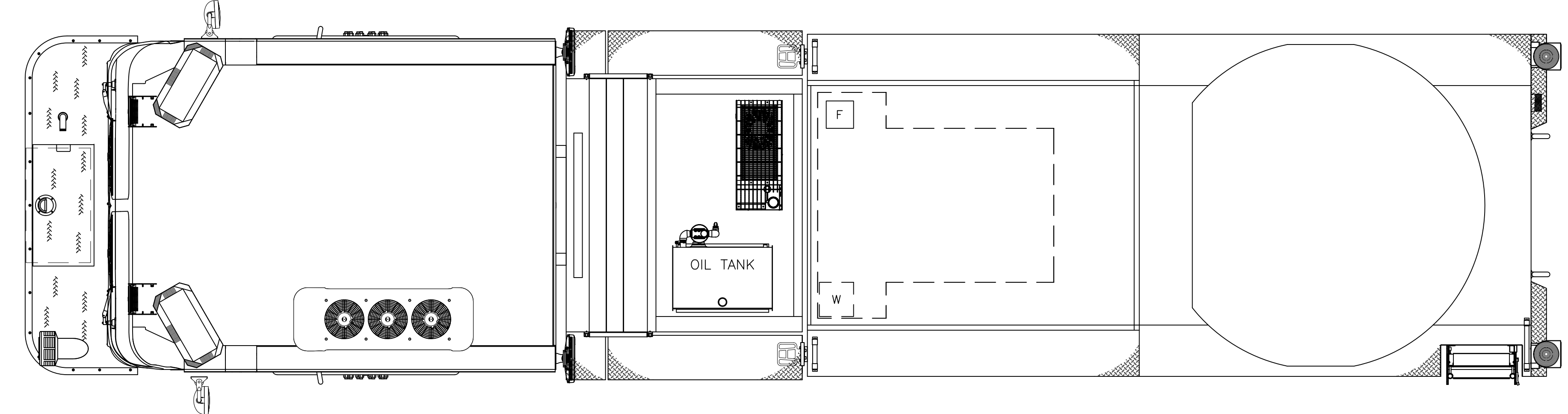

GROUND LADDERS & PIKE POLES			
ITEM	DESCRIPTION	MODEL #	QTY
A	35' 3 SEC EXTENSION	1225-A	1
B	24' 2 SEC EXTENSION	900-A	1
C	18' ROOF	875-A	1
D	14' FRESNO ATTIC	701	1
E	10' FOLDING ATTIC	585-A	1
F	4' D-HANDLE AM HOOK	DLR SPLY	1
G	4' D-HANDLE DW HOOK	DLR SPLY	1
H	6' NY HOOK	DLR SPLY	2
I	8' NY HOOK	DLR SPLY	1
J	10' AM HOOK	DLR SPLY	1

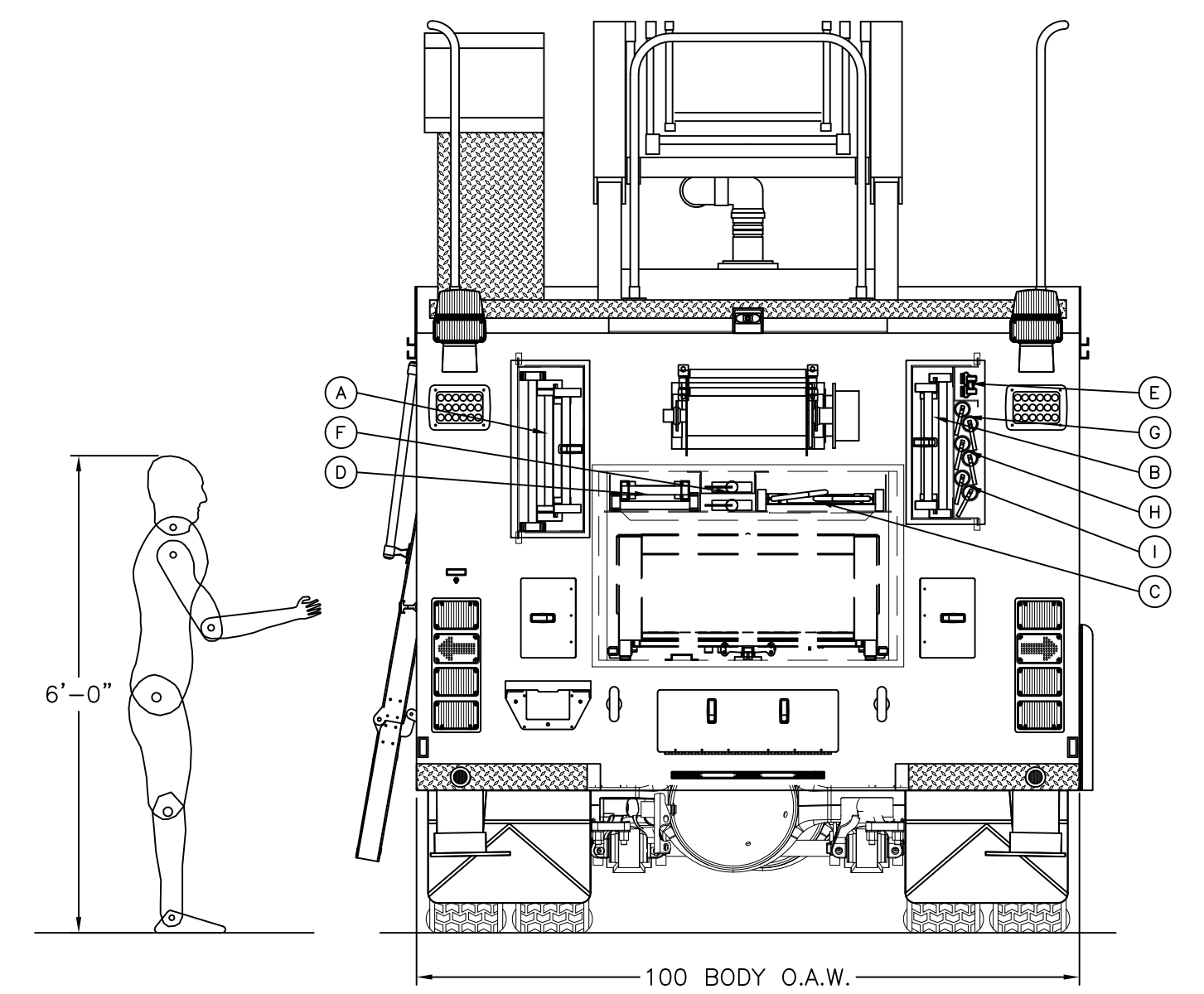
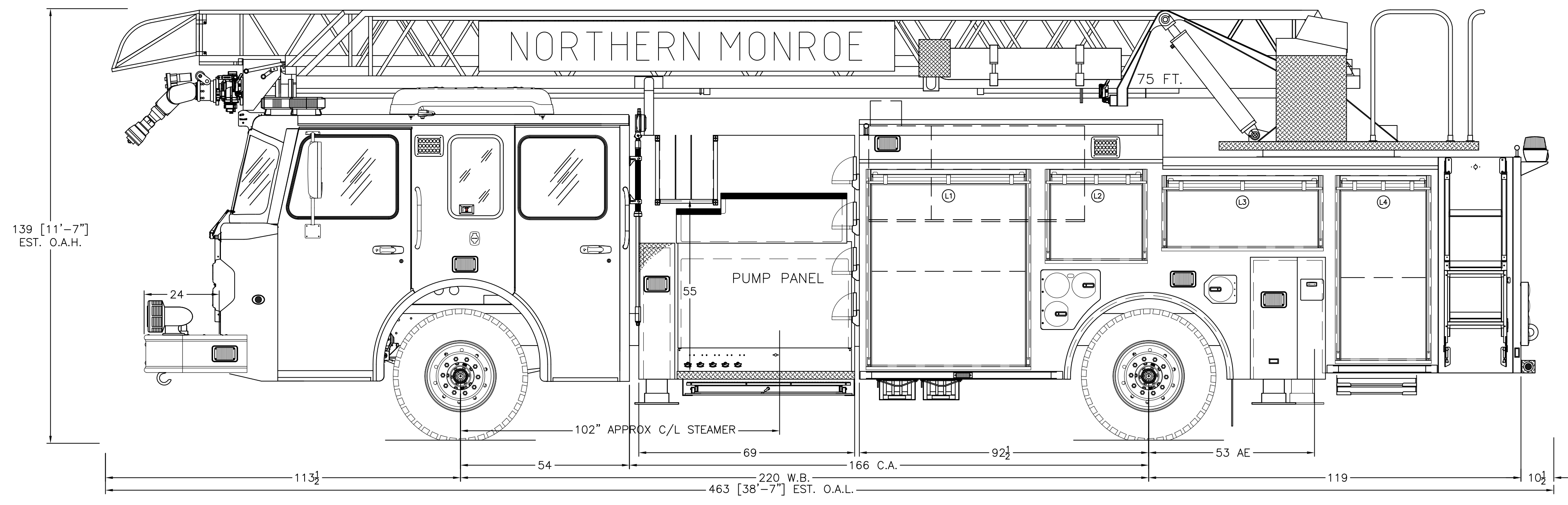

NOTE:
 THIS DRAWING IS THE PROPERTY OF SPARTAN MOTORS USA AND IS TO BE USED ONLY IN REFERENCE TO THE WORK PROPOSED OR CONTRACTED BY SPARTAN MOTORS USA ANY REPRODUCTION IN PART OR IN WHOLE WITHOUT THE WRITTEN PERMISSION OF SPARTAN MOTORS USA IS STRICTLY PROHIBITED.
 DIMENSIONS SHOWN ARE APPROXIMATE AND ARE SUBJECT TO CHANGE AS MAY BE FOUND NECESSARY DURING CONSTRUCTION. THIS DRAWING MUST BE PLOTTED TO THE PAPER SIZE LISTED IN THE TITLE BLOCK FOR THE LISTED SCALE TO BE VALID.
 THIS DRAWING IS FOR REFERENCE PURPOSES ONLY. SOME ITEMS MAY OR MAY NOT APPEAR ON THE DRAWING THAT MAY OR MAY NOT BE INCLUDED IN THE SPECIFICATIONS. THE SPECIFICATIONS SHALL BE THE FINAL AUTHORITY TO DETERMINE WHAT IS SUPPLIED ON THE APPARATUS.

REV.	INT.	DATE	REVISION HISTORY DESCRIPTION
00	CL	9/10/19	INITIAL DRAWING 20569
01	Brodd	11/04/19	ORIGINAL LAYOUT

**PROPOSAL
 WORK IN PROGRESS**

CHASSIS: SPARTAN METRO STAR MFD FLAT ROOF
 ENGINE: CUMMINS L9 450HP WITH ALLISON 3000 EVS
 PUMP: DARLEY LDM
 WATER TANK: 350 U.S. GAL
 FOAM CELL: 20 U.S. GAL
 BODY MATERIAL: 1/8" ALUMINUM
 HOSE BED: 1000' OF 5" EHL
 GENERATOR: SMART POWER 6KW HR6

SMEAL
 A SPARTAN MOTORS BRAND
 610 W 4TH ST
 SNYDER, NE
 PHONE: (402) 568-2224
 WWW.SMEAL.COM

NORTHERN MONROE FIRE TERRITORY BLOOMINGTON, IN			
MODEL:	75' REAR MOUNT AERIAL (S33RL-75)		
DEALERSHIP:	HOOSIER FIRE EQUIPMENT, INC.		
SCALE:	1/2" = 1'	DRAWN BY:	D.Brodd
DATE:	11/04/19	DRAWING NO.:	20644
SIZE:	24" X 36"	REV.:	01
SHEET:	1 OF 1		